

2.65 ± 0.15

PART NUMBER CODING

MPMS30-1 XX XX X 100 X 1

No. of Pins
02-38pin

Contact Plating

- G0:Gold Flash
- G1:3U*Gold
- G2:5U*Gold
- G3:10U*Gold
- G4:15U*Gold
- G5:20U*Gold
- G6:30U*Gold
- S0:Gold Flash/Tin
- S1:3U*Gold/Tin
- S2:5U*Gold/Tin
- S3:10U*Gold/Tin
- S4:15U*Gold/Tin
- S5:20U*Gold/Tin
- S6:30U*Gold/Tin
- SN:Tin

Insulator
Material/Colour
A:PPS/Black

Packing
A:Tray
B:PE Bag
T:Tube

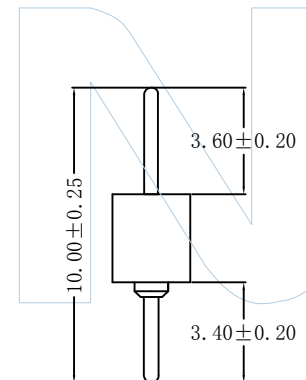
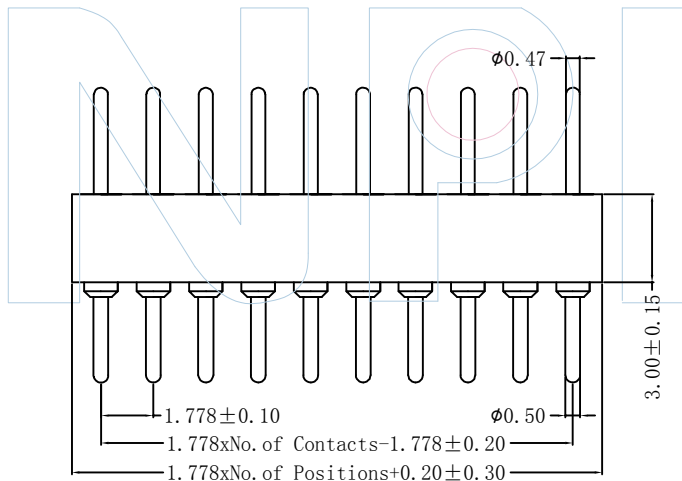

Tel: +86 769 82581808 FAX: +86 769 81766192
 E-Mail: sales@winpin.net Http: www.winpin.net

PART NO: MPMS30-1XXXXX100X1

TITLE: 1.778mm Machined Pin Header Single Row 180°
 H=3.00 L=10.0

NOTES:
 Current Rating: 1.0AMP
 Contact Resistance: 10mΩ Max
 Withstand Voltage: 1000V AC/DC
 Mechanical Life: Min 500 cycles
 Connecting Pin: $\phi 0.47$ mm
 Operation Temperature: -40°C to +105°C

Material:
 Sleeve: Brass
 Contact Plating: Au or Sn over Ni
 Insulator Material: PPS(UL94V-0)

UNLESS OTHERWISE SPECIFIED DIMENSIONS ARE IN METRIC
 TOLERANCES ARE:
 DECIMALS Angle
 X.X: ±0.40 ± 3°
 X.XX: ±0.25
 X.XXX: ±0.15

SCALE	1:1
UNIT	MM
PROJ.	
SHEET	

A0	2015/06/25	NEW	Huan.Tan		Huan.Tan
REV	DATE	MODIFICATION DESCRIPTIO	DRAW	CHANGE	APPROVE