

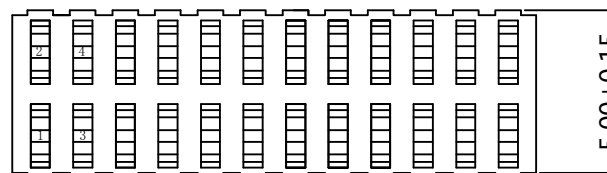

Recommended P.C.B Layout(Top Side)
(PCB BOARD TOLERANCE±0.05)

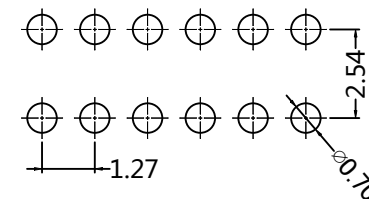

PART NUMBER CODING

FHDS46- 2 XX XX X Y X 2

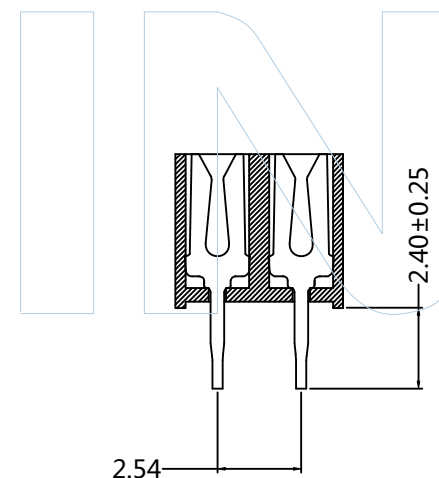
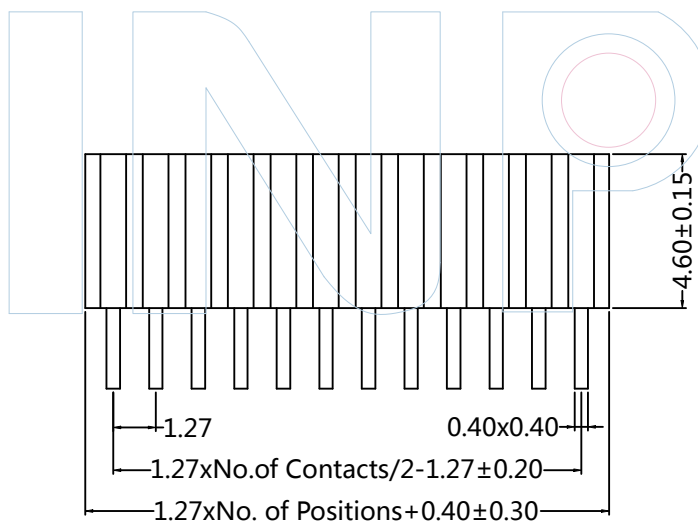
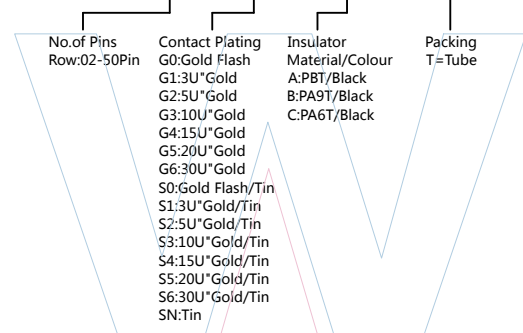

Tel: +86 769 82581808 FAX: +86 769 81766192
E-Mail:sales@winpin.net Http://www.winpin.net

PART NO: FHDS46-2XXXXXX2

TITLE: FH1.27*2.54mm Dual Female 180° H=4.6mm

NOTES:
Current Rating:1.0AMP
Contact Resistance:20mΩ Max
Insulation Resistance:1000MΩ Min
Withstand Voltage:500V AC/Minute
Operation Temperature:-40°C to +105°C

MATERIAL:
Contact Material:Phosphor Bronze
Contact Plating:Au or Sn over Ni
Insulator Material:PBT/PA9T/PA6T+30%GF (UL94V-0)

UNLESS OTHERWISE SPECIFIED DIMENSIONS ARE IN METRIC TOLERANCES ARE:
DECIMALS Angle
X.X:±0.40 ± 3°
X.XX:±0.25
X.XXX:±0.15

SCALE	1:1
UNIT	MM
PROJ.	
SHEET	

A0	2015/06/25	NEW	Huan.Tan		Huan.Tan
REV	DATE	MODIFICATION DESCRIPTIO	DRAW	CHANGE	APPROVE